



Triangle BioSystems, Int'l.

32 Channel Wireless Neural Headstage System



Headstage Features

- Wireless operations across 4 meters
- Operates in unlicensed radio band below FCC limits
- Available with 31 channels
- Factory configurable gain of 800
- Rechargeable battery power with 5.0 battery life
- Bandpass filtering per channel
.9Hz to 7kHz typical
- 50kHz sampling rate per channel
- Weight: 4.8 grams

Triangle BioSystems, Int'l. has developed a high channel count wireless neural headstage system that allows researchers to continuously and simultaneously monitor up to 31 neural electrodes. No longer do experiments have to be constrained by wiring a test subject to the recording system. The complete system is comprised of a wireless headstage transmitter with integrated battery, RF signal receiver/baseband demodulator, power supply and all required cables. With an effective range of 4 meters, this system provides a wireless connection between the implanted electrodes and the data recording system.

In the development of this system, TBSI utilized custom ASIC technology and proprietary radio design techniques to provide high channel count functionality in a wireless headstage that is both small and light weight of 4.8 grams for the 25mil connector. This design also incorporates neural preamplifier circuitry to create an extremely compact and powerful transmitter.

Neural Recording System Overview

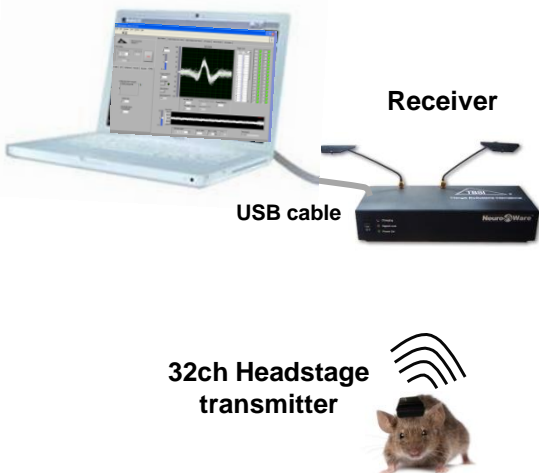

System Block Diagram

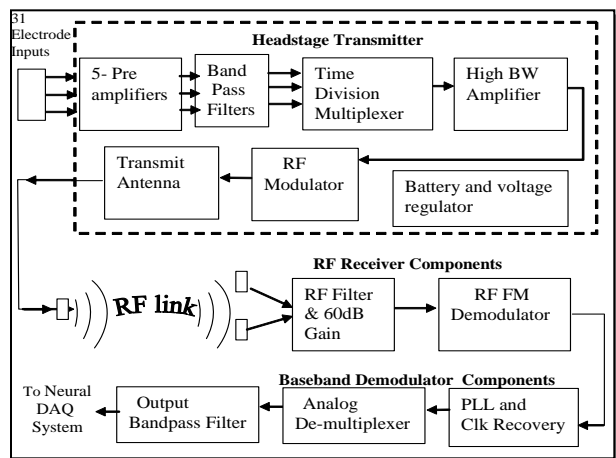

Headstage Specifications

Electrical

Parameter	Min	Typ	Max	Units	Notes
Power Supply					
3 volt supply		2.95	3.0	Volts	Power consumption 11.0ma (typical)
Battery life		5.0		Hours	Re-chargeable battery with 2 hour recharge time
Analog Input Specs					
Input voltage range		6		mVolts	Maximum Input voltage Vp-p
Common mode center		.9		Volts	At ACgnd potential
Gain selection	790	800	810		Factory selectable gain
Bandwidth	.9		7000	Hz	-3dB input signal level BW
Input impedance		11M		ohms	At 1kHz
Input referred noise		8.5		µVrms	for DC - 10khz frequency
Input referred noise		5.5		µVrms	for 500Hz – 5kHz frequency
Sampling Rates		100		kHz	Headstage and DAC sampling rates per channel
Mechanical Specs					
Length		17		mm	Edge to Edge
Width		19		mm	Edge to Edge mounting holes (#0-80 screws)
Height		8		mm	Not including connector
Weight			4.8	grams	4 grms w/25mil connector. 4.6grams w/50mil.
Input connector					Omnetics Female 18 pin dual row nano 25 mil Omnetics Female 20 pin dual row, 50 mil
Radio Specs					
Center frequency		3.05		GHz	With +/- 100 MHz bandwidth
Transmit power			300	µW @ 3 meters	FCC Sec.15.109B(a)
Transmit antenna		3.05		GHz	Tuned chip antenna with circular diversity
Transmit range		4.0		Meters	With receiver on top of cage

Mechanical (mm)

Top View

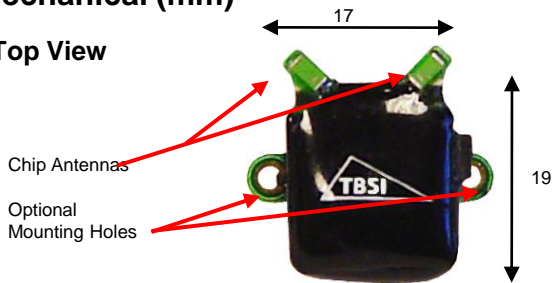

Bottom View

36 pin Omnetics, 25Mil Female w/guide pins

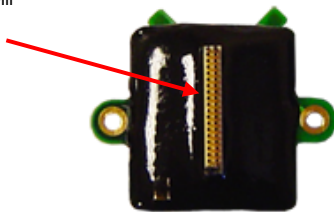

Analog RF ASIC

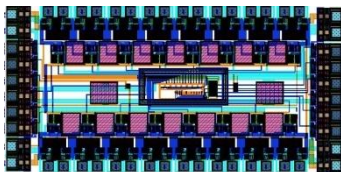

Connector Information

Omnetics 50mil dual row

Omnetics Male, Dual Row 25 mil nano, 36 pin

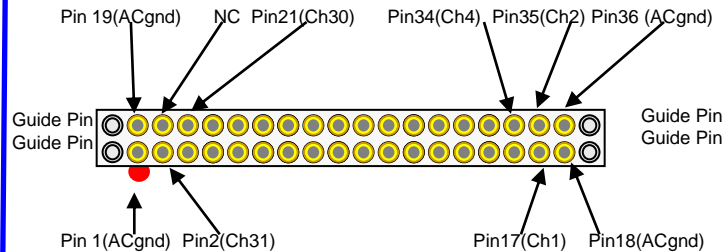

Ordering Information

16-Channel Wireless Headstages

Part No.	Battery Operating Time	Battery Type	Connector Pins
32RadioHS	5.0 hour	Internal	36
36RadioHS_24H	24 hour	External	18
32NeuroRadioRX	Wireless Receiver/Demodulator		

TBSI