



Triangle BioSystems, Int'l.



32 Channel, Gain 20 and 100 Tethered Headstages

Headstage Features

- Custom VLSI circuit provides small size & reduced weight
- Weight < 0.8 grams
- 34 channels total (32 data channels and 2 reference channels)
- Available with gain of 20 and 100
- Unity gain ground buffer output
- Selectable bandpass filtering per channel
- 3v/5v operation
- Size: 3x14x20 mm

Triangle BioSystems, Int'l. offers a family of 32-channel analog headstage subassemblies that are used to provide a wired connection between implanted electrodes and neural recording and analysis equipment. The main function of the headstage is to precondition the neuron pulse signals and provide a high gain, bandpass filtered buffered connection over a low impedance cable. Each headstage design is based on a custom, low power VLSI developed by TBSI. The result is a solution with superior performance in a very small form-factor with less weight.

The 32-channel high gain, bandpass filter headstages are available with gains of 20 and 100 with a selectable bandpass filter.

System Overview



NeuroWare™ Certified

Block Diagram

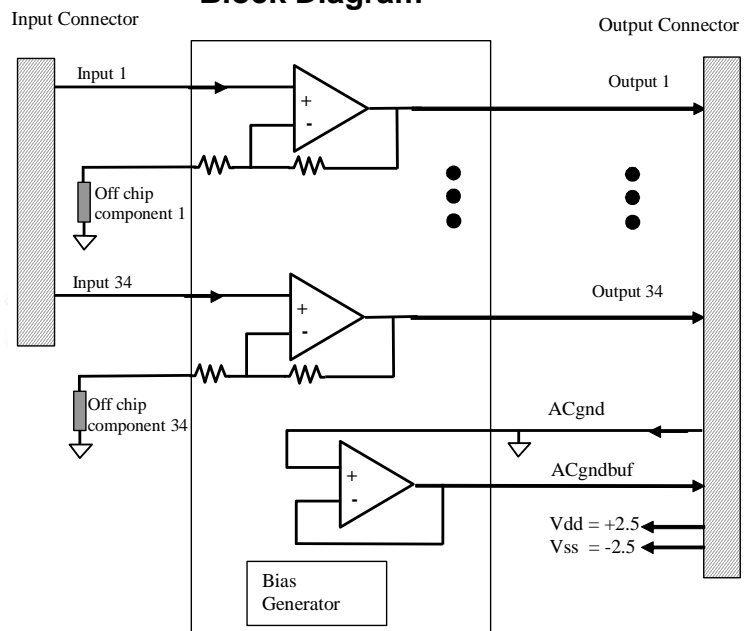

Headstage Specifications

Electrical

Parameter	Min	Typ	Max	Units	Notes
Power Supply					
3 volt supply	3.0	3.3	3.6	Volts	3.3v Bipolar power supply (+/- 1.65v)
Average Icc 3v	5.6	6.1	6.7	ma	
5 volt supply	4.5	5	5.5	Volts	5v Bipolar power supply (+/- 2.5v)
Average Icc 5v	6.8	7.5	8.5	ma	
Analog Channel					
Input voltage range (5v)	-1.2	0	1.8	Volts	For 5v Bipolar power supply
Input voltage range (3.3v)	-6		.8	Volts	For 3.3v Bipolar power supply
Common mode center		0		Volts	For bipolar power supplies only
dc Offset	-10	0	10	mVolts	For bipolar power supplies only
Gain 20	19	20	21		Factory selectable gain
Gain 100	95	100	105		Factory selectable gain
G20 Bandwidth @ 5v	.8		150	kHz	-3dB input signal level BW
G100 Bandwidth @ 5v	.8		25	kHz	-3dB input signal level BW
Input impedance		50		Mohms	At 1kHz
Output impedance		158		ohms	At 1kHz
Input referred noise		5.1		μVrms	for DC - 10kHz frequency with all inputs grounded
THD			-63	dB	@ 5kHz and 1 volt p-p input
Phase Delay		30		uSecs	@ 5 kHz input
Settling Time		5.5		uSecs	With 1v step input
Mechanical Specs					
Length		20		mm	Edge to Edge of connector pins
Width		14		mm	
Height		3.0		mm	
Weight			.8	grams	
Miscellaneous					
Reference Bias Current		78		uA	Included inside headstage
Junction Temperature	-40	25	100	C	

Custom VLSI ASIC

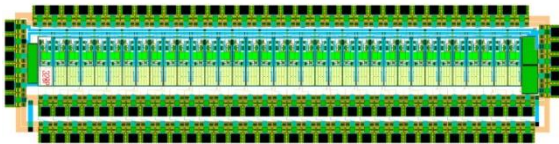

Compact Size Headstage

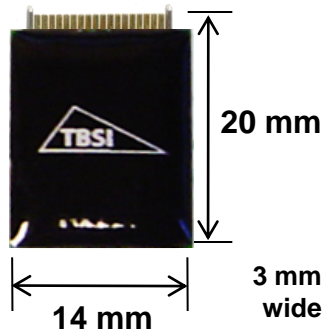

Headstage Connectors

Looking At Input Connector (Omnetics A8829) From Probes:

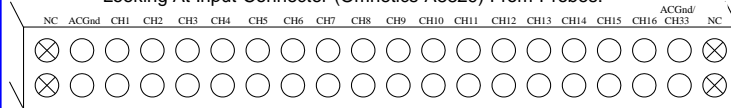

Looking At Output Connector (Omnetics A8830) From Monitor Side:

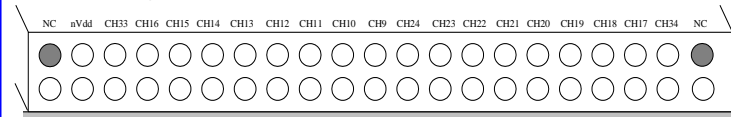

Ordering Information

Part No.	Gain	BP Filter
Neuro34BPG20	Gain 20	Yes
Neuro34BPG100	Gain 100	Yes
A9114 Electrode Cable	12 inches	
A9115 Record Cable	36 inches	

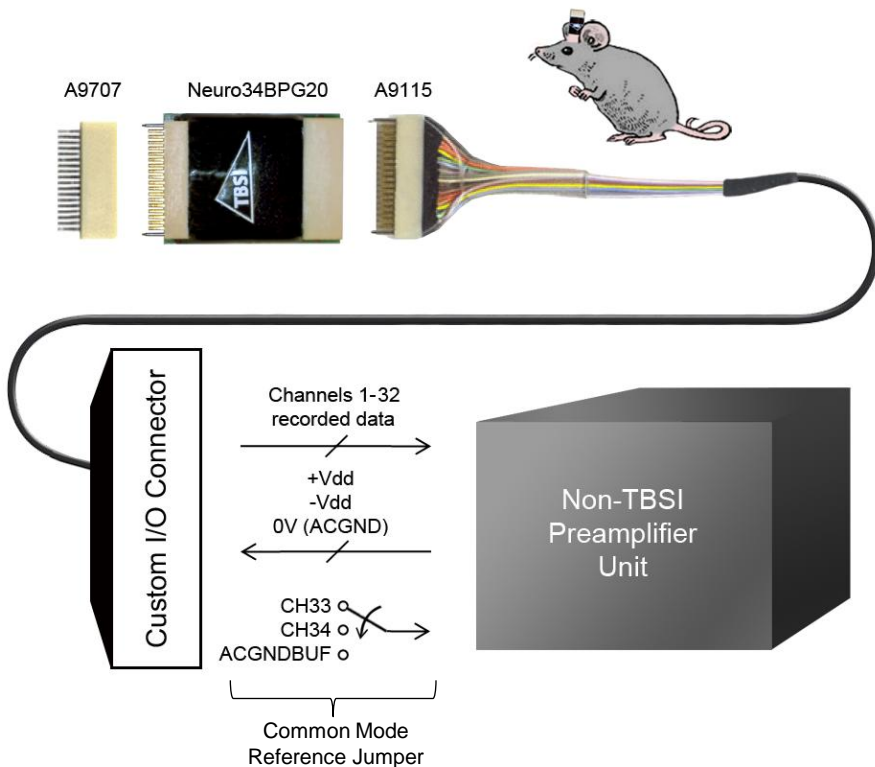

Available Grounding and Referencing Connections for T32G20,100 Headstage:

ACGND: Connect your animal ground to ACGND (see pinout diagram on pg2) of the headstage. This is typically connected to earth or system ground (which is 0V potential) of the recording system.

CH33,34: These are extra recording channels that can be used as common mode reference signals for external preamplifiers. These common mode reference channels are useful for removing animal movement artifacts or any other common mode noise found at the headstage input pins.

ACGNDBUF: With ACGND as the positive input, this pin uses a unity gain source follower to provide another common mode reference option for the preamplifier. NOTE: The ACGNDBUF is DC coupled with unity gain and does not have the same bandpass filter characteristics as channels 1-34. Therefore the common mode noise rejection when using ACGNDBUF may not be as effective as channels 1-34.

Front View

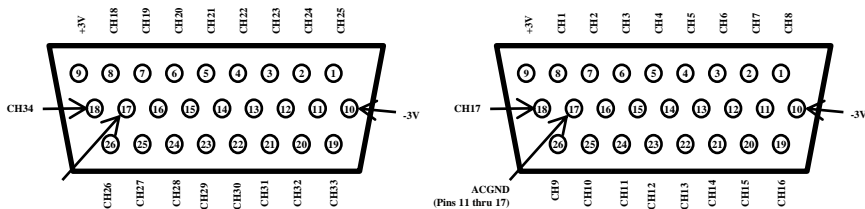

Rear View



* USB power option not available for 32ch T-series recording unit

Gain 20

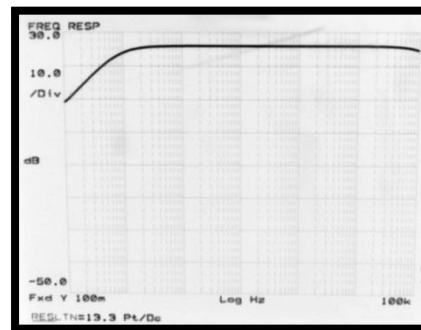

Gain 100

