

Compact Wireless Neural Recording System for Small Animals Using Silicon-based Probe Arrays

Patrick Ruther, *Member, IEEE*, Tobias Holzhammer, Stanislav Herwik, P. Dylan Rich,
Jeffrey W. Dalley, Oliver Paul, *Member, IEEE*, and Tahl Holtzman

Abstract—This paper reports on a compact, small-scale neural recording system combining state-of-art silicon-based probe arrays with a light-weight 32-channel wireless head stage. The system is equipped with two- and four-shaft, comb-shaped probe arrays connected to highly flexible ribbon cables enabling a reliable and controlled insertion of probe arrays through the intact dura mater into the medial prefrontal cortex and nucleus accumbens of rats. The *in vivo* experiments applied the 5-choice serial reaction time task (5-CSRTT) using freely behaving rats in order to understand the neural basis of sustained visual attention and impulsivity. The long-term stability of the system allowed local field potential (LFP) activity to be recorded without a significant decrement in signal quality for up to 28 weeks, and similarly, we were able to follow single unit activity for up to 4 weeks.

I. INTRODUCTION

Understanding brain circuits and relating their activity to behavior requires the large-scale recording of neuronal activity in freely behaving animals. In many laboratories, small animals such as rats and mice are the species of choice; however, their small size combined with the requirement to express natural behaviors requiring free movement poses substantial technical challenges for the implementation of large-scale neuronal recording. We have overcome these barriers by designing a multi-site silicon probe system that interfaces with the latest miniature wireless technology for small animals. In this way, limitations of tethered recording setups such as (i) restricted animal movements resulting in disturbed behaviour, (ii) the possibility of costly damage caused by animals chewing cables and connectors, and (iii) the need for expensive wire commutators that avoid cable tangling but introduce additional noise, are circumvented. Our *in vivo* experiments were conducted in rats undergoing behavioral testing using the 5-choice serial reaction time task (5-CSRTT, [1,2]). In short, the task requires animals to detect a brief, i.e., 0.5 s, stimulus light flash in one of five nose recessed apertures.

Manuscript received March, 25, 2011.

P. Ruther, T. Holzhammer, S. Herwik, O. Paul are with the Department of Microsystems Engineering (IMTEK), University of Freiburg, Germany (phone: +49/761-203-7197; fax: +49/761-203-7192; e-mail: ruther@imtek.de, tobias.holzhammer@imtek.de, herwik@imtek.de, paul@imtek.de).

T. Holtzman, P.D. Rich and J.W. Dalley are with University of Cambridge, Department of Experimental Psychology, Cambridge, UK (th247@cam.ac.uk, pdr27@cam.ac.uk, jwd20@cam.ac.uk). J.W. Dalley is also affiliated to the Department of Psychiatry at the University of Cambridge.

This study was funded by Howard Hughes Medical Institute Janelia Farm Research Campus.

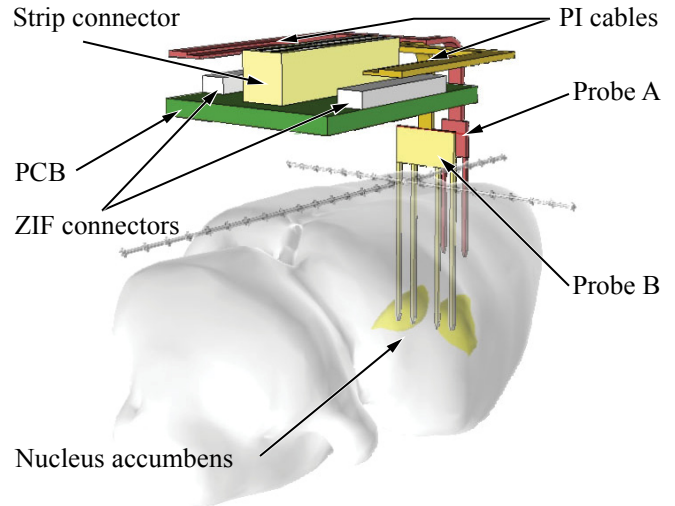

Figure 1: Schematic of the probe system comprising two silicon-based probes connected to a custom PCB.

Nose pokes to the illuminated aperture are rewarded with the delivery of a food pellet whereas responses made before the stimulus or to the incorrect aperture result in the withholding of the food pellet. This test assesses behavioral control and impulsivity, facets of which may predispose individuals to stimulant addiction [3]. To elucidate the neural basis of behavioral performance on this task, we recorded neural activity from both sides of the brain in two key structures involved in impulsivity, the medial prefrontal cortex (mPFC) and nucleus accumbens (NAc). We demonstrated that local field potential (LFP) activity can be recorded for extended time periods (up to 28 weeks) alongside with single neuron recording (up to 4 weeks) using our silicon-based probe arrays. This advance promises to open new avenues of combined behavioral and neurophysiological research in freely behaving small animals.

II. METHODS

The neural system applied in this study comprises two custom made comb-like electrode arrays attached to highly flexible ribbon cables, a dedicated interfacing printed circuit board (PCB) $16 \times 20 \text{ mm}^2$ in size to interface the probes with a light-weight wireless head stage, as schematically shown in Fig. 1.

A. Neural probe

The silicon-based neural probes comprise slender probe shafts (width $w_s = 140 \mu\text{m}$ and thickness $t_s = 100 \mu\text{m}$) attached to a probe base, as shown in Fig. 2. Circular

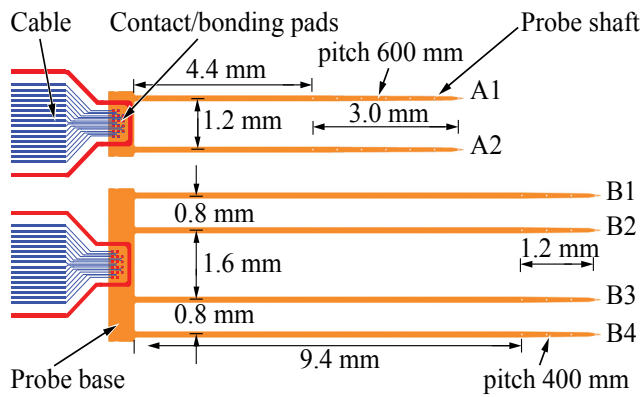

Figure 2: Layout of probe variants A and B and sections of the PI cables (left).

platinum (Pt) or iridium oxide (IrO_x) electrodes with a diameter of $35 \mu\text{m}$ are arranged along the probe shafts and connected to corresponding bonding pads on the probe base using $5\text{-}\mu\text{m}$ -wide metal lines. Two probe comb variants with two and four probe shafts carrying 14 and 16 electrodes, respectively, have been realized, as shown in Fig. 2. The shaft length and shaft pitch of variant A are $l_{s,A} = 7.4 \text{ mm}$ and $p_{s,A} = 1.2 \text{ mm}$, respectively, while the design parameters of variant B are $l_{s,B} = 10.6 \text{ mm}$ and $p_{s,B1} = 0.8 \text{ mm}$ and $p_{s,B2} = 1.6 \text{ mm}$. The interelectrode distances of variants A and B are $p_{e,A} = 600 \mu\text{m}$ and $p_{e,B} = 400 \mu\text{m}$, respectively. Although both probe variants differ in the number of electrodes, the same bonding pad arrangement is applied on the probe base. As a consequence, two electrodes of variant A are each connected to two bonding pads.

The probes are assembled to highly flexible ribbon cables comprising a 300-nm -thick Pt metallization sandwiched between two $5\text{-}\mu\text{m}$ -thick polyimide (PI) layers (U-Varnish S, UBE Europe GmbH, Germany), as shown in Fig. 3. They comprise bonding and contact pads to interface with the probe and a commercial zero insertion force (ZIF) connector, respectively. In the current version of the probing system, a ZIF connector is used with a pitch of $500 \mu\text{m}$ between individual contacts. The two 90° -kinks in the cable (cf. Fig. 3) are motivated by the interconnection scheme of the probes and the wireless headstage, as illustrated in Fig. 1. This scheme applies a printed circuit board (PCB) carrying

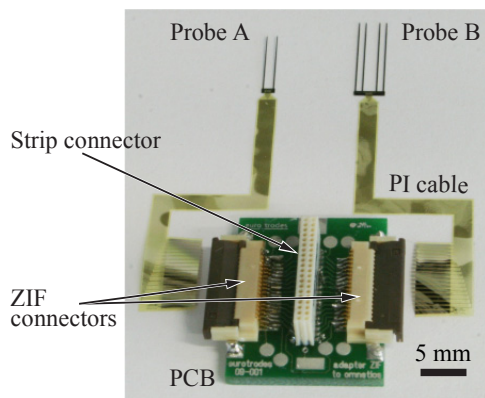

Figure 3: Recording system with probe variants A and B, highly flexible ribbon cables and a dedicated PCB.

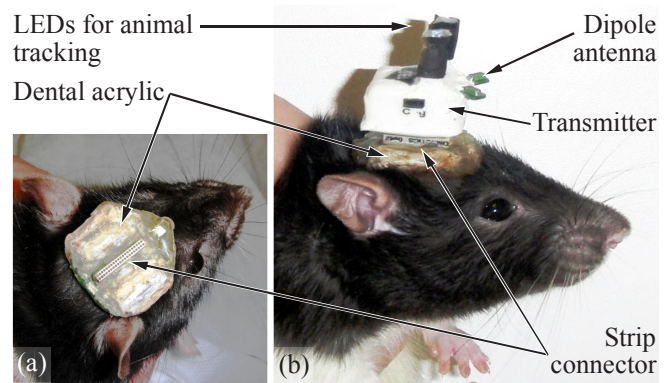

Figure 4: Lister-Hooded rat with (a) translucent dental acrylic-encapsulated interfacing PCB and (b) wireless 32-channel headstage connected to the PCB.

two ZIF connectors facing opposite sides of the PCB and a high-density strip connector (NPD-36-VV-GS, OMNETICS, MN, USA) positioned in-between (cf. Fig. 3). Consequently, two different cable layouts are required for the probe to be connected to the left or right ZIF connector. However, as we apply the same bonding pad arrangement on both probe variants, the cables apply the same but mirrored layout. This enables, in principle, to apply either cable variant with each of the probes.

The realization of probes and cables are detailed elsewhere [4-6]. Briefly, the fabrication process of the probes applies standard thin film technologies, i.e., plasma enhanced chemical vapor deposition, sputtering and reactive ion etching (RIE), to deposit and pattern insulation and passivation layers and to define the metallization of contact pads and leads as well as the Pt or IrO_x electrodes. Furthermore, the etching-before-grinding (EBG) process [6] based on deep reactive ion etching (DRIE) combined with wafer grinding is used to define the probe shape and thickness, respectively. The cables are fabricated by spin-coating a first $5\text{-}\mu\text{m}$ -thin polyimide layer on a 4-inch wafer. The PI layer is cured at 400°C . The metallization is then deposited and patterned using sputtering and lift-off followed by processing the second PI layer. Both PI layers are patterned using RIE in an oxygen plasma to define the cable shape and to clear openings to the bonding and contact pads [7]. Finally, a $7\text{-}\mu\text{m}$ -thick gold layer is deposited onto the bonding and contact pads using electroplating, following which the cables are peeled off the wafer. Cables and probes are assembled using flip-chip-bonding [7] and an adhesive underfill to stabilize the bond.

B. Wireless head stage

The wireless headstage (32-channel Wireless Neural Headstage System, Triangle BioSystems (TBSI), NC, USA) applied in this study first amplifies and filters the signals recorded by the neural probes with a gain of 100 and a second order cascaded bandpass filter from 0.8 Hz to 10 kHz , respectively. The signals from the 32 channels are then multiplexed at 50 kHz into a single output channel. The multiplexed signal is transmitted via a frequency modulated radio-frequency (RF) signal at 3.05 GHz . The entire headstage weighs 4.5 g and is equipped with a rechargeable

45 mAh lithium ion battery. The FM signal is broadcast in a radius of 4 m via two dipole antennas mounted orthogonally to each other and picked up by a receiver connected to the data acquisition system. In addition, the transmitter comprises two LEDs for video tracking of the animals during the experiments. Details on the wireless headstage system are described elsewhere [8]. Figure 4 (b) shows the headstage connected to the strip connector on the interfacing PCB fixed on the head of a Lister-Hooded rat. For comparison, Table 1 summarizes relevant system parameters of the applied wireless headstage and those of a recent telemetry system introduced by T.A. Szuts et al. [9].

Table 1: Performance of telemetry systems [8,9].

	This study	Szuts et al. [9]
Channel count	32	64
Weight	4.5 g	52 g
Transmission range	4 m	60 m
Size	2.2 cm ³	> 60 cm ³
Battery lifetime	5 h	6 h
Transmitter frequency	3.05 GHz	2.38 GHz
Bandwidth		
low cut-off	0.8 Hz	10 - 100 Hz
high cut-off	7,000 Hz	50 - 4,500 Hz
Gain	800	1,800
Sampling rate	50 kHz	20 kHz

C. Animal preparation and surgery

All procedures were approved by the local ethical review panel of the University of Cambridge and by UK Home Office regulations in accordance with the Animals (Scientific Procedures) Act of 1986. Fourteen Lister-Hooded rats (400 - 450 g) were anesthetized with isoflurane and placed into a standard stereotaxic frame. The Bregma skull-landmark was exposed and a small craniotomy was made rostral to this. Three custom-modified M1.6 stainless steel bolts were implanted into the skull as anchor points - one also served as the recording reference electrode. We implanted rats with the silicon-based probe arrays (cf. Fig. 2) to target the medial prefrontal cortex (mPFC; bregma +2.8 mm, ~0.7 mm lateral, 2 to 5.5 mm deep) and ventral striatum (NAc; bregma +1.8, 0.8 & 1.8 mm lateral, -6.5 to -8.5 mm deep) on both sides of the brain. Our probes were designed to record from the anterior cingulate, prelimbic and infralimbic cortices, alongside the core and shell sub-regions of the NAc. Local field potential activity (LFP) and single unit activity (SUA) data were sampled using the data acquisition software Sciworks (Datawave Technologies, CO, USA) at 1.5 kHz (LFP) and/or 25 kHz (SUA), amplified and filtered (gain = 20, AM4000, AM systems WA, USA) at 1 to 500 Hz or 500 Hz to 10 kHz for LFP or SUA, respectively. Video signals were also sampled at 25 Hz, synchronized to the neural data, to allow motion tracking during the task.

Prior to surgery, animals had been trained on the 5-CSRTT, a common task in the study of sustained attention and impulsivity in rodents and analogous to continuous performance tests in humans [1]. Testing was performed in an operant chamber (25×25×25 cm³, Med Associates, VT, USA) housed in a sound attenuating chamber. The wireless receiving unit was placed inside the sound attenuating chamber with a continuous direct line of sight to the animal / transmitter.

D. Probe insertion and fixation

Probe handling and manipulation was achieved using a custom-made vacuum holder designed to fix the flexible cable part of the probes [10]. The vacuum holder was mounted in a standard stereotaxic frame with a sufficient number of degrees of freedom to align probes to the stereotaxic frame to ensure verticality and zero yaw prior to implantation. Additional temporary bonding was achieved using a droplet of poly-ethylene glycol (Mw ~1500, Sigma Aldrich, UK). Typically, probes were inserted directly through the intact dural membranes without breakage or subsequent damage. Once lowered to the target depth, a small amount of glass ionomer cement (GC FujiCEM, UK) was applied to bond the first of the two probes to the skull. Following cement curing (~5 min.), the second probe was inserted 1.2 mm in front of the first probe using the same procedure. Once fixed, the remainder of the headpiece was built using dental cement (Kemdent, UK) thereby providing a foundation for the PCB interconnect (cf. Fig. 4 (a)). The flexible cables were then inserted into the ZIF connectors, impedance tested and sealed with clear silicone sealant (3M, USA). Following this, all exposed parts were encapsulated with translucent dental cement and animals were allowed to recover.

III. EXPERIMENTAL RESULTS

A. Probe characterization

After probe assembly, the electrode impedance was determined using a three-electrode setup, i.e., a Pt counter electrode, an Ag/AgCl reference electrode and the micro electrode as working electrode, in combination with an electrochemical impedance analyzer (CompactStat, Ivium Technologies, The Netherlands). Impedance values of 666±143 kΩ at 1 kHz were extracted for the Pt electrodes. In the case of the IrO_x electrodes, representative impedance values of 211±80 kΩ were obtained. Typically, a yield higher than 95% of functional recording sites was achieved per assembled neural probe.

B. Neural recordings

We were able to record LFP activity from all 30 recording sites of both probes. In agreement with previous studies in the ventral striatum of awake rats [11-13], the LFP signals were punctuated by bouts of high amplitude gamma-band oscillatory activity. These oscillations were strongly harmonic with a frequency centered around 55 Hz and typically lasting 100 to 500 ms. LFP traces from an example animal are shown in Fig. 5 (a), highlighting pronounced gamma-band activity, evident as bouts of oscillatory activity. Gamma-band oscillations were also accompanied by prominent activity at other frequencies including <10 Hz, ~20 Hz and 80 - 100 Hz, broadly in agreement with previous studies. We were also able to record well isolated single unit activity in addition to LFP signals. Representative data are shown in Figs. 5 (b) and (c), illustrating a pair of NAc neurons recorded simultaneously on the same electrode in an awake rat. The activity of these neurons is illustrated in the firing rate histograms shown in Figs. 5 (b) and (c). In both

cases, the firing rates were reduced for ca. 500 ms following the nose-poke responses (time = 0) required during performance of the 5-CSRTT. Approximately 1 s after nose poke responses, animals received food rewards, corresponding to the increased firing rate seen in the histograms. Superimposed spike waveforms of each neuron are presented alongside. It was not uncommon for multiple spike waveforms to be isolated on the same electrode, giving our best total yield of up to 14 units spread across 12 electrodes in the PFC and NAc on both sides of the brain. We recorded LFP activity without significant decrement in signal quality for up to 28 weeks, and similarly, once the probes had stabilized post-surgery we were often able to follow single unit activity across many days (up to 4 weeks).

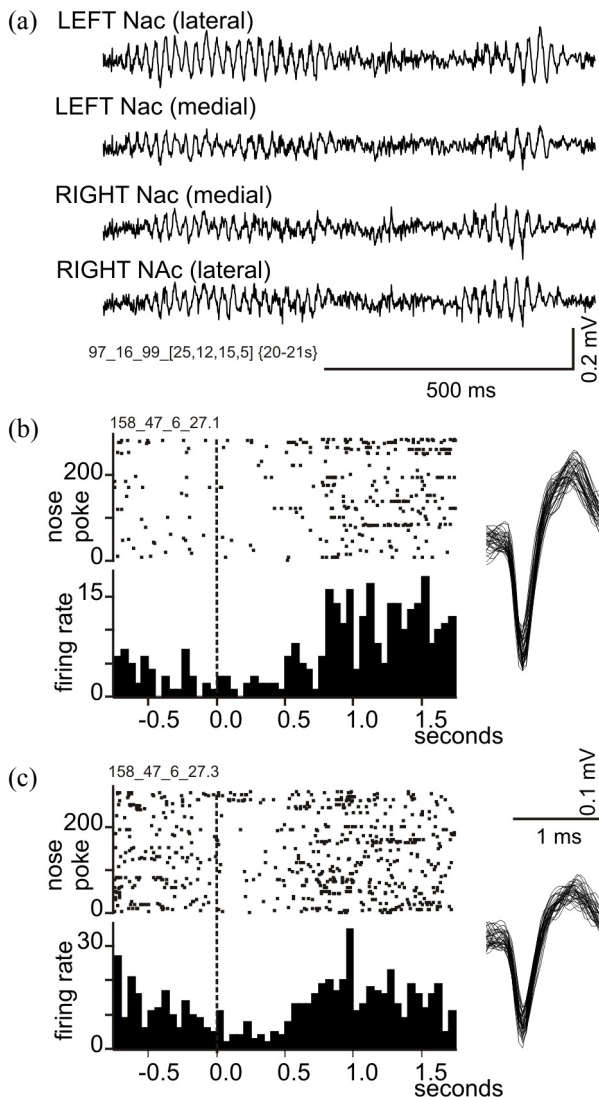

Figure 5: Neuronal activity recorded in awake rats; (a) Traces of LFP activity recorded in four sites on a variant B probe implanted in the NAc; prominent gamma-band activity is seen across the array. (b,c) Activity of two simultaneously recorded neurons in the NAc during performance of the 5-CSRTT. Data are aligned by nose-poke responses (time = 0, bin-width = 50 ms).

IV. CONCLUSION / DISCUSSION

This paper presented a compact wireless neural recoding system used to record simultaneously from the medial prefrontal cortex and nucleus accumbus in freely behaving animals in the 5-CSRTT task. The system applies silicon based probe arrays with two and four shafts carrying a total of 30 Pt electrodes. The interconnection of the probes with a commercial wireless headstage uses highly flexible ribbon cables and an interfacing PCB. Long-term LFP recordings as long as 28 weeks have been performed.

ACKNOWLEDGMENT

The authors wish to thank Sebastian Kisban (IMTEK-MML) for his support in designing the probe arrays and flexible cables and Michael Reichel and Armin Baur (both IMTEK-RSC) for technical support during clean room processing.

REFERENCES

- [1] T. Robbins, The 5-choice serial reaction time task: behavioural pharmacology and functional neurochemistry, *Psychopharmacology*, vol. 163, 2002, pp. 362-380.
- [2] A. Bari, J. Dalley, T. Robbins, The application of the 5-choice serial reaction time task for the assessment of visual attentional processes and impulse control in rats. *Nature Protocols*, vol. 3(5), 2008, pp.759-67.
- [3] J.W. Dalley, T.D. Fryer, L. Brichard, et al. Nucleus accumbens D2/3 receptors predict trait impulsivity and cocaine reinforcement, *Science*, vol. 315, 2007, pp. 1267-1270.
- [4] S. Herwik, S. Kisban, A.A.A. Aarts, et al., Fabrication technology for silicon-based microprobe arrays used in acute and sub-chronic neural recording, *J. Micromech. Microeng.*, vol. 19, 2009, 074008 (11pp)
- [5] P. Ruther, S. Herwik, S. Kisban, et al., Recent Progress in Neural Probes using Silicon MEMS Technology, *IEEJ Trans. Electrical and Electronic Eng.*, vol. 5, 2010, pp. 505-515.
- [6] S. Herwik, O. Paul P. Ruther, Ultrathin Silicon Chips of Arbitrary Shape Realized by Etching-Before-Grinding Technology, *JMEMS*, 2011, doi:10.1109/JMEMS.2011.2148159.
- [7] S. Kisban, J. Kenntner, P. Janssen, et al., A Novel Assembly Method for Silicon-Based Neural Devices, *IFMBE Proc. 25/IX, Proc. World Congress on Med. Phys. Biomed. Eng.*, September 7 - 12, 2009, Munich, Germany, pp. 107-110
- [8] D. Fan, D. Rich, T. Holtzman, et al., A wireless multi-channel recording system for freely behaving mice and rats, *PLoS One*, accepted for publication.
- [9] T.A. Szuts, V. Fadeyev, S. Kachiguine, et al., A wireless multi-channel neural amplifier for freely moving animals, *Nature Neurosci.*, vol. 14 (2), 2011, pp. 263-269.
- [10] S. Kisban, P. Janssen, S. Herwik, et al., Hybrid microprobes for chronic implantation in the cerebral cortex, in *Proc. 30th Annual Int. Conf. of the IEEE Engineering in Medicine and Biology Society EMBS 2008*, (2008), pp. 2016-2019.
- [11] J.D. Berke, Fast oscillations in cortical-striatal networks switch frequency following rewarding events and stimulant drugs, *Eur. J. Neurosci.*, vol. 30 (5), (2009), pp. 848-859.
- [12] M.A. van der Meer, A.D. Redish, Low and High Gamma Oscillations in Rat Ventral Striatum have Distinct Relationships to Behavior, Reward, and Spiking Activity on a Learned Spatial Decision Task, *Front. Integr. Neurosci.*, vol. 3, (2009), pp. 1-19.
- [13] T. Kalenscher, C.S. Lansink, J.V. Lankelma, C.M. Pennartz, Reward-associated gamma oscillations in ventral striatum are regionally differentiated and modulate local firing activity, *J. Neurophysiol.*, vol. 103 (3), (2010), pp. 1658-1672.